

4 Basic Circuits II

Student Group

First Name	Surname	Matrikel Nr.

Table of Contents

4. Basic Circuits II	2
Introductory example	2
Objectives for Basic Circuits II	2
4.1 Reverse shredder	3
Exercise 4.1.1 Transfer exercise - signals and systems	4
4.2 Differential amplifier / subtractor	4
4.3 Instrumentation Amplifier	6
Exercise 4.3.1 Instrumentation amplifier	7
4.4 Current-Voltage-Converter	8
4.5 Voltage-to-Current Converter	9
Tasks	10
Exercise 4.2.1 Determination of the transmission behavior of the differential amplifier	11
Exercise 4.4.1 Transmission resistance of the current-voltage converter	12
Exercise 4.5.1 Transfer Conductance of the voltage-current converter	13
Exercise 4.5.2 Earth-related load	14
Further Reading	14
Learning Questions	14

4. Basic Circuits II

- Also recommended for basic circuits II is the <https://www.ablic.com/en/semicon/products/analog/opamp/intro/>
- [Operational Amplifiers \(Johan Huijsing\)](#) [viewable via the university network]

Introductory example

In various applications, currents must be measured. In an electric motor, for example, the torque is caused by the current flowing through the motor. A motor control and also a simple overcurrent shutdown is based on the knowledge of the current. For further processing, a voltage must be generated from the current. The simplest current to voltage converter is the ohmic resistor. A sufficiently large voltage as required by a microcontroller, for example, cannot be achieved with this. So not only the current has to be converted, but also the generated potential difference has to be amplified.

One such current sense amplifier is the [INA 240](#) device. This is installed as shown below. In the simulation, a real current source feeds the electrotechnical image of a DC motor on the left (in the example: inductance with $L_L=10\text{mH}$ and internal resistance $R_L=1\Omega$). The current flowing from the motor is conducted through a measuring resistor ($R_M=0.01\Omega$) which is noticeably smaller than the internal resistance of the motor. Thus, most of the power acts in the motor and the current is only marginally affected by the sense resistor. The simulation on the right shows the inner workings of the current measuring amplifier.

The following explains ways in which such circuits can be understood.

Objectives for Basic Circuits II

After this lesson, you should:

1. Be able to apply the superposition method to operational amplifier circuits.
2. Know how differential amplifiers and instrumentation amplifiers differ (circuit, applications, advantages and disadvantages).
3. Know what the circuit and transfer function of a voltage-to-current converter and current-to-voltage converter look like.
4. Be able to name applications for the inverse-radiator, voltage-to-current converter, and current-to-voltage converter.

4.1 Reverse shredder

Fig. 1: Reverse shredder

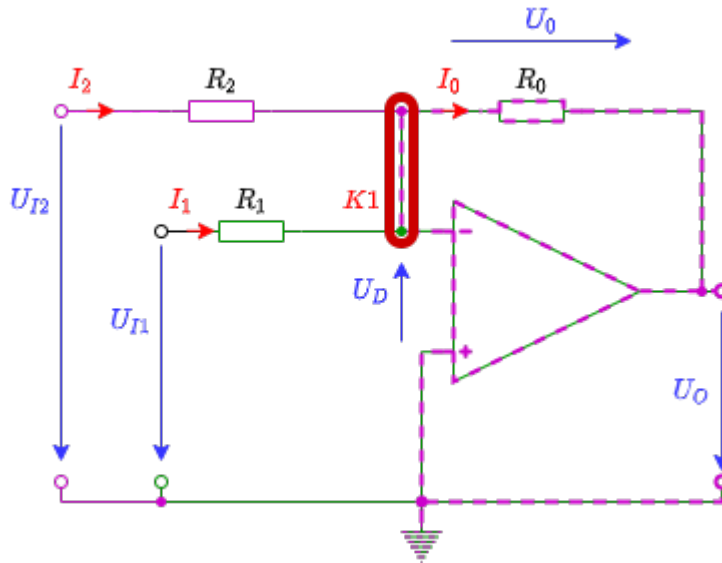

From the [inverting amplifier](#) another circuit can be derived, which can be seen in [figure 1](#). Here, both the green part of the circuit and the purple part correspond to an inverting amplifier.

How can U_A be calculated in this circuit? To do this, it is first important to understand what is being sought (compare [steps to the goal](#)). The goal is to find the relationship between output and input signals: $U_A(U_{E1}, U_{E2})$. Different ways to get there were explained in [Electrical engineering 1: Analysis of dc networks](#). Here we will now outline a different way.

In the case of a circuit with several sources, superposition is a suitable method, in particular the superposition of the effect of all sources in the circuit. For superposition, it must be ensured that the system behaves linearly. The circuit consists of ohmic resistors and the operational amplifier. These two components give twice the output value when the input value is doubled - they behave linearly. For superposition, the effect of the two visible voltage sources U_{E1} and U_{E2} must be analyzed in the present circuit.

In **case 1** the voltage source U_{E1} must be considered - the voltage source U_{E2} must be short-circuited for this purpose. The equivalent circuit formed corresponds to an inverting amplifier across R_2 and R_0 . However, there is an additional resistor R_1 between the inputs of the operational amplifier. What is the influence of this resistor? The differential voltage U_D between the inputs of the operational amplifier approaches 0. Thus, the following also applies to the current through R_1 : $I_1 \rightarrow 0$. Thus the circuit in case 1 is exactly an inverting amplifier. For case 1, $U_A^{(1)} = \frac{U_A^{(1)}}{U_{E1}} = -\frac{R_0}{R_1}$ and thus: $U_A^{(1)} = -\frac{R_0}{R_1} \cdot U_{E1}$.

Using the same procedure, **case 2** for considering the voltage source U_2 gives: $U_A^{(2)} = -\frac{R_0}{R_2} \cdot U_{E2}$.

In superposition, the effect results from the **addition of partial effects**:

$$\boxed{U_A = \sum U_A^{(i)} = -\left(\frac{R_0}{R_2} \cdot U_{E2} + \frac{R_0}{R_1} \cdot U_{E1}\right)}$$

Also, considering the node set for $K1$ in [figure 1](#) gives the same result.

The reverse adder can be extended to any number of inputs. The simulation on the right shows the superposition of several inputs. Depending on the resistances at the different inputs, a different current flows into the circuit.

This circuit was used in analog [audio mixers](#). This allows to combine several signals with different gain (by the input resistors R_i with $i=1, \dots, n$). Furthermore, the overall gain can be changed by R_0 . A big advantage of this circuit is also that the summation at node $K1$ is done on potential U_D . This means that capacitive interference with respect to the ground potential is virtually non-existent.

A very similar concept allows the construction of a [digital-to-analog converter digital analog converter, DAC](#).

Exercise 4.1.1 Transfer exercise - signals and systems

1. Which mathematical function seems to be visible from the superposition of sinusoidal signals, when these sinusoidal signals double the frequency and halve the amplitude? (This is the output of the simulation above..)
2. Which mathematical function seems to be visible in the simulation, when the voltage sources with $80 \text{ ~}\mu\text{m Hz}$ and $160 \text{ ~}\mu\text{m Hz}$ are removed?

4.2 Differential amplifier / subtractor

In addition to the (reverse) adder, there is also a circuit for subtracting two input values. This circuit became the core of the introductory example. But also in the simulation below this circuit is shown in another example: In this case, a [differential input signal](#) is shown on the left. Differential means that the signal on one line is not transmitted with respect to a reference voltage (usually ground potential) on a second line. Instead, the signal is transmitted to both lines in opposite directions. If a disturbance acts equally on both lines (which is often the case when lines are close to each other), the effect of the disturbance can be eliminated by forming the difference.

How can the relationship $U_A(U_{E1}, U_{E2})$ between output and input signals be determined for this circuit?

Fig. 2: Difference Amplifier

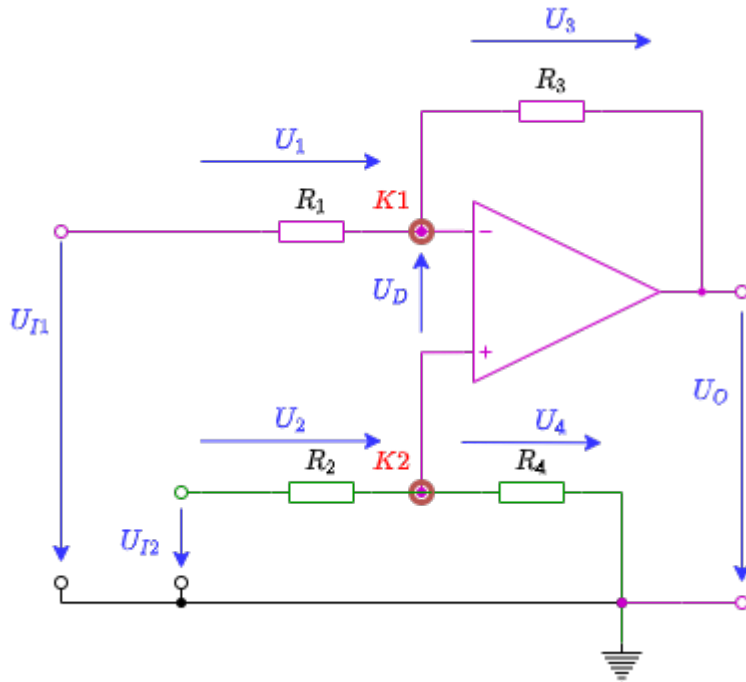

Again, various network analysis concepts could be used to look at the circuit (e.g. superposition or mesh and node sets). Again, another possibility is to split the circuit as color-coded in the figure 2. The green part shows a voltage divider $R_2 + R_4$. Since the input resistance of the operational amplifier is very large, this voltage divider is unloaded. The voltage at node K_2 or at the noninverting input U_p is just given by the voltage divider: $U_p = U_{E2} \cdot \frac{R_4}{R_2 + R_4}$.

The violet part corresponds to an inverting amplifier, but the voltage at the node K_1 or at the inverting input U_m is just equal to U_p due to the feedback, since $U_D \rightarrow \infty$. Thus, the current flowing into node K_1 via R_1 results from $I_1 = \frac{U_{E1} - U_p}{R_1}$. The output voltage is given by $U_A = U_p - U_3$, where the voltage U_3 is given by the resistance R_3 and the current through R_3 . The current through R_3 is just the same as the current through R_1 , i.e. I_1 .

The result is:

$$U_A = U_{E2} \cdot \frac{R_4}{R_2 + R_4} - R_3 \cdot \frac{U_{E1} - U_p}{R_1}$$

$$U_A = U_{E2} \cdot \frac{R_4}{R_2 + R_4} - U_{E1} \cdot \frac{R_3}{R_1} + U_{E2} \cdot \left(\frac{R_3}{R_1} \cdot \frac{R_4}{R_2 + R_4} \right)$$

$$\boxed{U_A = U_{E2} \cdot \frac{R_4}{R_2 + R_4} \cdot \frac{R_3 + R_1 + R_3}{R_1} - U_{E1} \cdot \frac{R_3}{R_1}}$$

Fig. 3: Differenzverstärker - Animation

Zur Betrachtung der Animation: [hier klicken!](#)

Two simplifications should be considered here:

1. If $R_1 = R_2$ and $R_3 = R_4$ are chosen, the equation further simplifies to: $\boxed{U_A = U_{E2} \cdot \frac{R_3}{R_1} - U_{E1} \cdot \frac{R_3}{R_1} = \frac{R_3}{R_1} \cdot (U_{E2} - U_{E1})}$. This variant can be found in various measurement circuits.

2. Alternatively, if $R_1 = R_3$ and $R_2 = R_4$ is chosen, the result is:

$$U_A = U_{E2} - U_{E1}$$

This would also result in case 1. if $R_1 = R_2 = R_3 = R_4$ is chosen.

The animation on the right shows how the 2nd case would result with similar triangles. The connection of the two rockers at the point $K_1 K_2$ is caused by the operational amplifier, through which the voltage U_p and U_m converge to $U_D \rightarrow 0$.

A big advantage of this circuit is that even very large voltages can be used as input voltage if $R_1 \gg R_3$ and $R_2 \gg R_4$ are chosen. This would divide the input voltages down and display a fraction of the difference as the result. The main drawback of the circuit is that the gain/attenuation depends on more than one resistor. This makes a quick choice of gain difficult.

4.3 Instrumentation Amplifier

Fig. 3: Instrumentenverstärker

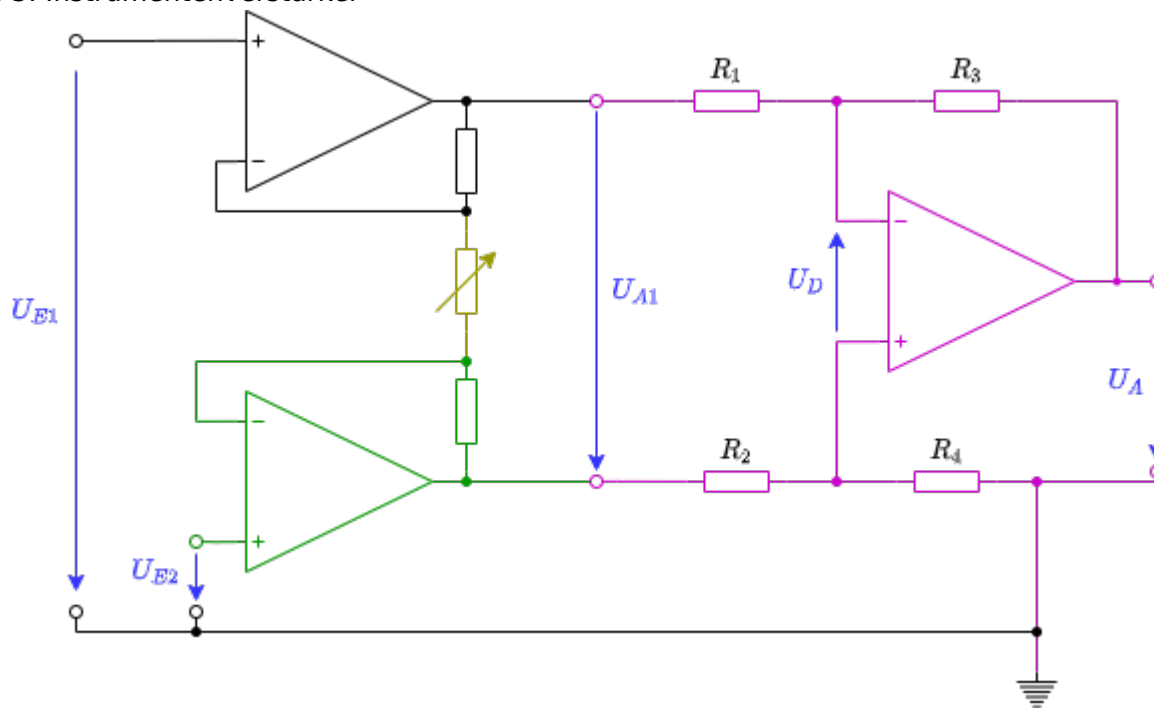

Exercise 4.3.1 Instrumentation amplifier

Find out how the instrumentation amplifier works through internet research.

1. Consider the illustrated Falstad Simulation below. What happens when you change the value of the variable resistance?
Analyze especially the minimum and maximum value of the output voltage.
In order to do so, you can start/stop the simulation with the Run/STOP button and read the output voltage by moving the mouse pointer over the output signal in the voltage-time diagram.
2. What happens if you remove the variable resistance and leave the connections open?
Which circuit has the OPVs at the entrance?

3. Compare the following situations. What is to be determined?
 1. Variable resistance is replaced by resistance with $2 \text{ k}\Omega$.
 2. Variable resistance is replaced at the top connection by $1 \text{ k}\Omega$ to mass and lower connection by $1 \text{ k}\Omega$ to mass.
 3. Variable resistance is replaced at the top connection by $1 \text{ k}\Omega$ to a voltage source with 1 V and the lower connection also by another $1 \text{ k}\Omega$ to 1 V .

4. Which transfer equation $U_{\text{A}} = F(U_2, U_1, R_{\text{G}}, R)$ does the initial circuit have, when all resistances (except the variable resistance R_{G}) have the same value R ?

5. What are the advantages of the instrumentation amplifier to the differential amplifier?

4.4 Current-Voltage-Converter

Fig. 5: current to voltage converter

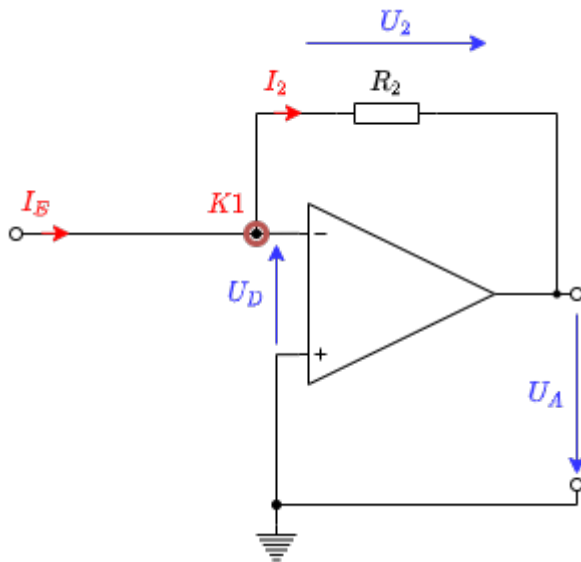

In [figure 5](#) you can see the circuit of a current-voltage converter. The current-to-voltage converter changes its output voltage based on an input current. This circuit is also called a [transimpedance amplifier](#) because here the transfer resistance - that is, the transimpedance - represents the gain. Generally, the gain was expressed as $A = \frac{\text{output}}{\text{input}}$. In the case of the current-to-voltage converter, the gain is defined as.

$$R = \frac{U_{\text{out}}}{I_{\text{in}}} = -R_1$$

R_1 is the resistor used in the circuit.

In the simulation, the slider on the right ("Current of current source") can be varied. This changes the input current and thus also the output voltage.

This circuit can be used, for example, to read a [photodiode in volt-free circuit](#) ([further explanation](#) and integrated circuit [tsl250r.pdf](#)).

4.5 Voltage-to-Current Converter

Fig. 6: voltag to current converter

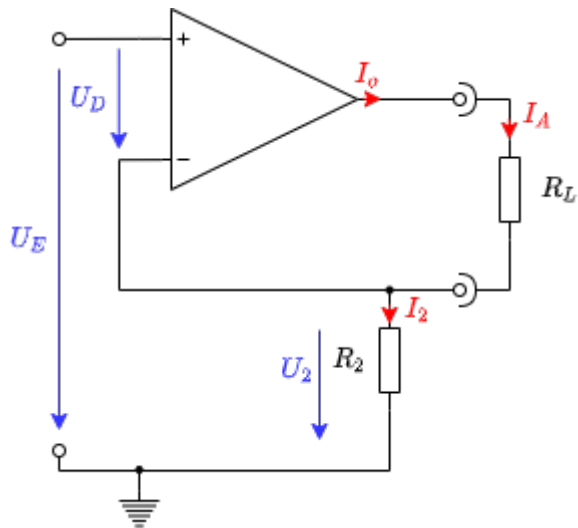

Next, consider the voltage-to-current converter. With this, an output current is set proportional to an input voltage.

Here, the general gain $A = \frac{\text{output}}{\text{input}}$ to

$$S = \frac{I_{out}}{U_{in}}$$

The quantity S is called the transmission slope or the transmission conductance.

This circuit can be used, for example, to generate a voltage-regulated current source.

Tasks

Übungsblatt 6

Bitte laden Sie das aufgefüllte PDF in ILIAS hoch.

Details, Tipps und Tools zum Ausfüllen und Einfügen von Bildern finden Sie unter:

[Tools für Lehr/Lern-Veranstaltungen](#)

Name	Vorname	Matrikelnummer

Exercise 4.2.1 Determination of the transmission behavior of the differential amplifier

In the following, the transfer function of the differential amplifier is to be calculated. To do this, you should follow a few steps.

1. Derive the function $U_{\text{O}} = f(U_{\text{I1}}, U_{\text{I2}})$ using superposition.
 1. To do this, first draw an equivalent circuit in each case.
 2. Briefly describe the resulting circuit. Which amplification circuit results in each case?
 3. Then calculate the voltages U_{O1} and U_{O2} , and from them U_{O} .
2. Determine the function $U_{\text{O}} = f(U_{\text{I1}}, U_{\text{I2}})$ or the resistance values of the circuit shown.

Exercise 4.4.1 Transmission resistance of the current-voltage converter

Derive the gain for the current-voltage converter, i.e. the transmission resistance. Use the procedure that we used for the other amplifiers.

1. Draw a circuit with the relevant voltages, currents, resistances, and the operational amplifier
2. What are you looking for?
3. What is the number of variables
4. What is the number of equations required?
5. Establishing the known equations.
6. Derivation of the transmission resistance.

Exercise 4.5.1 Transfer Conductance of the voltage-current converter

Derive the “amplification” for the voltage-to-current converter, i.e. the transfer conductance. Use the same procedure that we used for the other amplifiers.

1. Draw a circuit with the relevant voltages, currents, resistances, and the operational amplifier.
2. What are you looking for?
3. What is the number of variables?
4. What is the number of necessary equations?
5. Establishing the known equations.
6. Derivation of the transfer conductance.

Exercise 4.5.2 Earth-related load

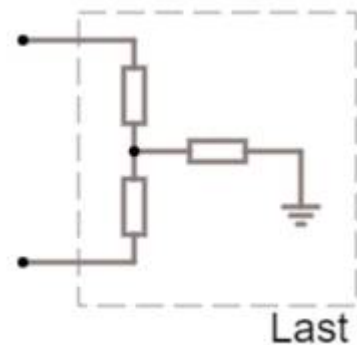

If the voltage-current converter is used as a current source, it must be ensured that the load has no contact with the ground.

1. Draw the voltage-to-current transformer with a load that is in contact with the ground.
2. Why is in this case the slope derived above no longer valid as an amplification factor?
3. Will the output current be higher or lower in this case?

Further Reading

- [Low Dropout Controller](#)

Learning Questions

- State applications for the reverse adder.
- Explain the working of a current to voltage converter.
- Name 3 applications for an operational amplifier.

From:

<https://wiki.mexle.te.hs-heilbronn.de/> - MEXLE Wiki

Permanent link:

https://wiki.mexle.te.hs-heilbronn.de/circuit_design/4_opamp_basic_circuits_ii?rev=1637096987

Last update: 2021/11/16 22:09

